



# PRODUCT MANUAL



## Solaris A20

---

# CONTENT

1. Introduction
  - Copyright
  - Limitation of Liability
  - Fields of application
2. Security notes
3. Precautions
4. Description of features
5. Test features
6. Components
7. Operation
8. Initial commissioning
9. Dispensing of water
10. Changing filters
  - Reset flashing filter warning
  - Replace Air filter
  - Replace water filters
  - Replace LED-UV lamp of the bottom tank
  - Replace LED-UV lamp of the top tank
11. Flushing, cleaning and disinfection
  - Flushing the device
  - Cleaning the bottom tank
  - Device disinfection
12. Connection of additional water sources
13. Complete drainage
14. Trouble shooting
15. Solutions of other problems
16. Technical specifications

- ◇ The Solaris-A20 must be in vertical position 24 hours before using.
- ◇ When using the new Solaris A20 at the first time, please be noted that it only supplies clean drinking water after the machine has been completely watered. (Please refer to 9. Dispensing of water).
- ◇ Do not forget to clean filters and change filters in time.

---

## 1. INTRODUCTION

Thanks for purchasing Solaris atmospheric water generator A20.

- ◇ No installation required for A20, just plug into the power source and follow the instructions in this manual.
- ◇ After switching on A20, the machine will start to produce, purify and store the cold and hot water up to 20 liters per day, based on the ambient temperature 30°C and related humidity 80%.
- ◇ A20 is easy to operate, environmentally friendly, clean and healthy.
- ◇ A20 can be used in household kitchen areas, offices, hotels, etc.
- ◇ A20 can be used by persons who are lack of experience and knowledge if they have been given supervision or instruction on using A20 in a safe way and understand the hazards involved. Suggest children under 8 years old shall not play with A20.
- ◇ Do not store explosive substances such as aerosol cans with a flammable propellant in A20.

### Copyright

This documentation is protected by copyright. Any reproduction, reprint, even partially as well as the reproduction of images, even in an altered state, is only allowed with the written consent of Solaris WaterGen

### Limitation of Liability

All technical information, data, wiring and operating instructions contained in this product manual correspond to the latest state of the art at the time of printing and have been made to the best of our knowledge and experience. No claims can be derived from the data, illustrations, and descriptions in this product manual. Solaris WaterGen is not liable for damages resulting from non-observance of the product manual, improper use, improper repairs, unauthorized changes, or the use of unauthorized spare parts.

### Fields of Application

A20 is designed exclusively for the water production from air above 15°C and 30% humidity environment condition.

Suggest A20 to be used indoors environment. If A20 is used in other environment where could lead to injuries and/or machine damage, Solaris WaterGen is not liable for any damage caused by improper use.

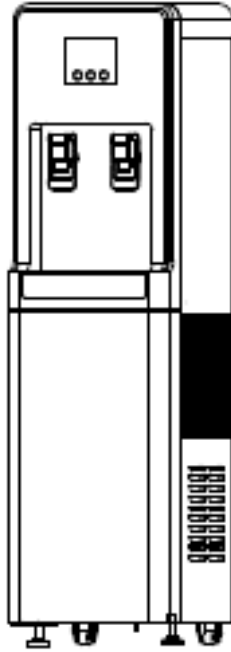

**Product Exterior Diagram**

## **2. SAFETY NOTES**

- 2.1. The electrical outlet shall be equipped with a reliable and correct grounding
- 2.2. Do not disconnect the grounding plug from the power cord
- 2.3. Do not use an extension cord or power adapter
- 2.4. Do not use damaged power cords or plugs
- 2.5. Always turn off the A20 by unplugging the power cord before servicing
- 2.6. Do not plug in or unplug the power cord with wet hands
- 2.7. Do not share the power outlet with other machines
- 2.8. Suggest to use replacements and consumables supplied by Solaris WaterGen
- 2.9. Improper repairing will not be protected by warranty policy
- 2.10. Unplug the power cord and empty the water from all tanks before moving A20
- 2.11. Do not tilt the A20 more than 20° while moving it. If the device is tilted by more than 20°, it must remain in an upright position for at least 24 hours before re-connecting to the power supply
- 2.12. Avoid prolonged eye contact with the ultraviolet LED-UV lamp
- 2.13. Warm water is heated to 92°C, please keep your body and skin away from the hot water to avoid injuries
- 2.14. CAUTION – LED-UV light source - disconnect the power supply from the LED-UV before opening the cover
- 2.15. CAUTION - TO AVOID RISK OF FIRE OR ELECTRIC SHOCK, USE THE MACHINE ONLY INDOOR. SEE FURTHER INFO IN PRODUCT MANUAL
- 2.16. Install A20 away from toxic gases or aggressive liquids



---

### 3. PRECAUTIONS

- 3.1. It is forbidden to install and use A20 in areas where there is a risk of explosion.
- 3.2. It is forbidden to install and use A20 in areas where the air contains oil, sulfur, chlorine or salt.
- 3.3. This A20 is not intended for outdoor use away from indoor areas
- 3.4. It is forbidden to wash A20 with a jet of water
- 3.5. Do not place any objects on the A20
- 3.6. It is forbidden to cover the intake and exhaust ports
- 3.7. It is forbidden to insert any objects into A20
- 3.8. It is forbidden to cover or move the switched-on A20
- 3.9. Operate A20 in an upright vertical position
- 3.10. All electrical cables must be secured against damage
- 3.11. Check that the extension cord meets the power, length, and destination requirements.
- 3.12. The switching voltage must not fall below 10% of the standard supply to avoid increased noise or overheating. If this happens, disconnect A20 from the power supply immediately until the voltage returns to normal
- 3.13. Young children must not use A20 without adult supervision
- 3.14. Position A20 in an area where it will not hinder or injure people by hitting the machine or spill water in the lower tank and cause an E7 error (see 14. Trouble shooting)
- 3.15. The A20 can only be operated in a vertical position, and the machine must be completely empty before each operation (see 13. Complete drainage)
- 3.16. Please follow product manual for detailed instructions before using A20
- 3.17. It is forbidden to use A20 for purposes other than those specified in this product manual
- 3.18. In case of non-observance of these instructions, Solaris WaterGen is not liable for any damages and the warranty cannot be applied

#### **Important electrical connection information**

A20 must be connected to the power source in accordance with current standards for power supplies equipped with static circuit breakers. If A20 is used in damp areas, the machine must be equipped with a static electricity circuit breaker which shall be provided by user to meet the conditions of such areas.

## 4. DESCRIPTION OF FEATURES

- 4.1. A20 uses an eight-stage filtration process to produce clean drinking water from the air. A20 extracts air through the ① Air filter which can prevent micro particles and dust entering into machine.
  - 4.2. The cleaned air and water vapor go inside and contact with the evaporator where the water vapor freeze due to compressor refrigerant in coils.
  - 4.3. Subsequently, the reverse function of the compressor heats up and the ice condenses into water, which drips into the water bowl of stainless steel, flows into the lower stainless steel tank, equipped with a ② LED UV lamp to remove bacteria and microorganisms.
  - 4.4. Hi-tech pump pushes the water through water filters including ③ sediment filter eliminating dirt and particles with a diameter of over 5 microns, further goes through ④ pre-carbon filter with coconut shells, which absorbs dangerous organic substances, such as chlorine, pesticides and some volatile organic compounds, and then through ⑤ membrane filter, eliminating micro-particles, plastics and particles of diameter less than 0.01 micron, through ⑥ Mineral filter with minerals beneficial to the human body (calcium, potassium, magnesium and sodium). subsequently through ⑦ Electropositive Membrane filter after sterilization. Then the water is pumped into an upper stainless steel tank equipped with an additional ⑧ LED UV lamp to ensure that no other bacteria or microorganisms remain in the water. If the ambient environment is not good or user needs soften water, the softening filter can be added which can adsorb ammonium, calcium ion, magnesium ion, etc.
- Two stainless steel tanks are located under the upper tank. One of them heats the purified drinking water to 92°C and the other cools the water to 6°C.

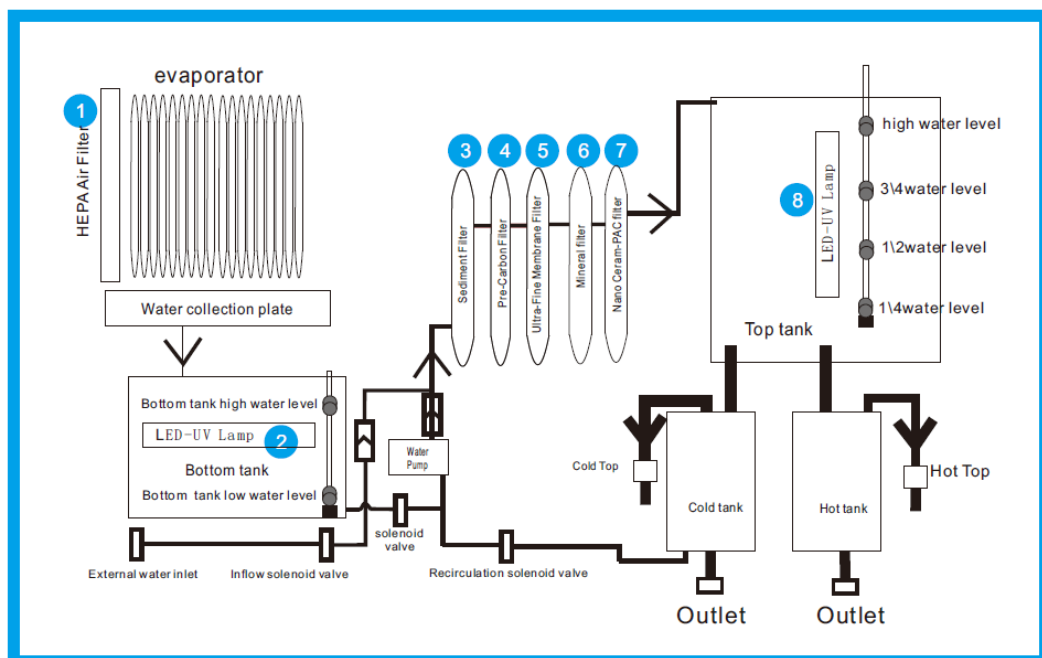

**Working principle diagram of A20**

Note:

A20L has 1 option of connecting to an additional water source to ensure that it can provide a constant supply of clean drinking water in all conditions even in periods of low humidity, which is not suitable for a normal operation.

Water from an external source can be filtered through the water filtration system in A20, especially when the external water source is not such clean as purified water, i.e. water supply from water factory, other external separate water tanks, etc. A20 will automatically switch to use an additional water source if water in internal water tank is below the level that required for dosing or when the relative humidity is lower than the operating humidity.

## 5. TEST FEATURES

It is important to note that the actual performance of A20 is based on physical laws, which depends on the relative humidity and ambient temperature. Relative humidity “RH” is ubiquitous and penetrates through all porous materials.

In general, the higher relative humidity and ambient temperature, the higher amount of water will be produced by HL-A20L. Water production is determined according to the table below.

Temperature/ Humidity	Tab. 1. Production of water per 24hrs [litres]						
	30%	40%	50%	60%	70%	80%	90%
15°C	-	2.56	3.50	4.50	6.40	7.00	9.10
20°C	-	4.16	5.70	6.40	7.90	9.01	12.43
25°C	3.85	5.27	7.20	9.10	12.80	15.30	18.82
30°C	4.92	6.74	9.20	12.60	17.70	20.00	25.20

The estimated 24 hours water production of A20 depends on the relative humidity and ambient temperature, generally provided by Mollier diagram (also IX HS or psychometric chart used by axis). HL-A20L can produce up to 20 liters of pure water from the air based on 30°C and RH 80%.

The operating environment condition range for HL-A20L is RH from 30% to 99% and temperature from 15°C to 45°C.

By considering optimal, cost-effective and safe use, A20 must comply with the following conditions:

1) A20 must be positioned at least 30 cm from any walls or other structures from all sides, such as by placing in the middle of the long wall for optimum air circulation in the space.

2) It is still necessary to supply fresh moist air, choose the location wisely, such as lobby, corridors, halls, auditoriums, covered terraces and roofs, kitchen, the dining room and forced air change, or high concentrations of relative humidity, such as gyms, winter gardens etc. Otherwise it may cause dry air in the room and improper machine operation.

3) A20 must not be installed next to radiators or heaters.

By the way, the best time of water production for some places is at night (due to higher relative humidity in the night).

---

## 6. COMPONENTS

6.1 Microcomputer - controls water production, collection, filtration, storage, heating, cooling and distribution of water that this device generates from the air

6.2. Electronic sensor - controls LED UV lamp, temperature, water levels, energy efficiency, maintenance, security and other features

6.3. Sensors for saving energy - control the process of making water from air with maximal efficiency

6.4. Hot water lock- prevents accidental dispensing of hot water from A20

6.5. Venturi blower - designed to provide maximum efficiency and reduced noise levels

6.6. Water leak detector - in case leaking, A20 will stop working and automatically displays error E7 on control panel (see 14. Trouble shooting)

6.7. Connection set - a set of water hoses can be connected directly to the tap or supply pipe, which allows A20 to function as a water purifier using a device filtering and disinfection system. Additional installation instructions (see 12. Connection of additional water sources)

6.8. Power switch - control the total power supply of A20. A20 start to work when it is turned on and stop working when it is turned off.

6.9. Hot water switch - hot water function, make sure that the hot water switch (red) is switched to "ON" position UP. Water heating switch must be turned on for at least 30 minutes, then the water can be heated to 92°C.

6.10. Cold water switch - cold water function, make sure that the cold water switch (black) is switched to "ON" position UP. Cold water switch must be turned on for at least 30 minutes, then the water can be cooled to 6°C.

6.11. 8 steps filtering process: the fan system extracts air and pushes it through the air filter. Water vapor in the air contact with the coils of stainless steel and condensation occurs, produces water. Then the water will pass through the next 7 steps filtration, which can remove chlorine fluoride, lead or other harmful ingredients, then produces up to 20 liters clean drinking water per day.

- ① Air filter - it prevents dust and micro particles penetration of the device and cleans air
- ② LED UV Lamp - kills bacteria and microorganisms (located in the lower tank)
- ③ Sediment filter (PPF) - eliminating dirt and particles having a diameter of over 5 microns
- ④ Pre-carbon filter (GAC) – charcoal and coconut shells absorbing hazardous organic compounds, such as chlorine, pesticides and some volatile organic compounds
- ⑤ Ultrafiltration Membrane filter (UF) – ultrafine filter eliminates particles smaller than 0.01 microns
- ⑥ Mineral filter (BIO) - with minerals beneficial to the human body (calcium, potassium, magnesium and sodium)

- ⑦ Electropositive Membrane filter (ELE) - principally use adsorption (electro-adhesion) as the filtering mechanism with absolute rating of 0.2micron to filter contaminants such as virus, bacteria, colloid, particulates, trace pharmaceuticals in the water.
- ⑧ LED UV lamp - kills bacteria and the remaining microorganisms (located in the upper tank)

6.12. Recirculated water - our exclusive technology ensures clean water recirculating through the internal water filters every three hours, so that the stored water always remains fresh and drinkable.

6.13. Protection against overheating - overheating protection will automatically switches A20 off when it detects overheating.

6.14. Protection against refrigerant leakage - A20 will be automatically switches off if refrigerant leak is detected.

### Arrangement device

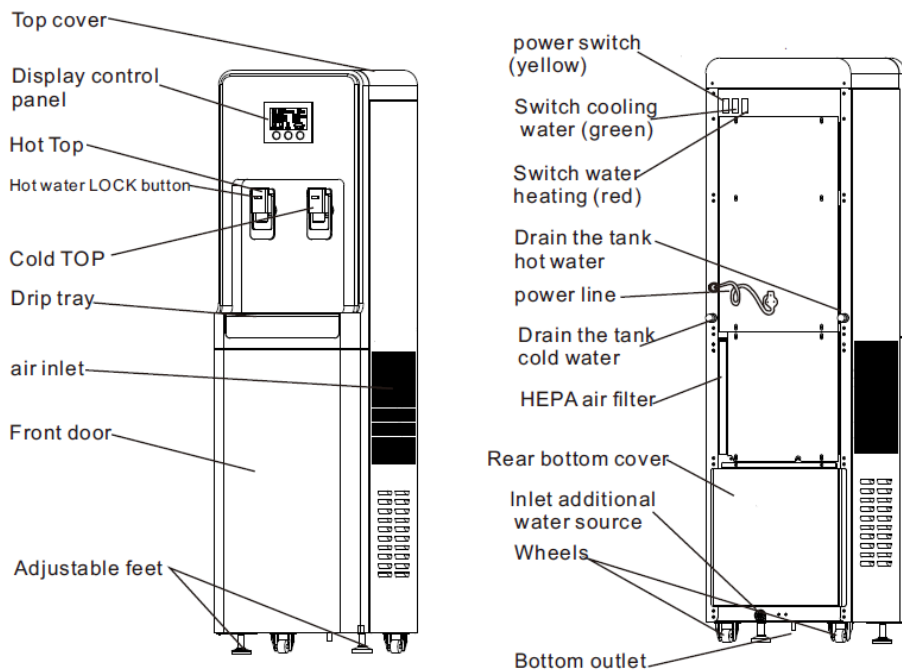

## 7. OPERATION

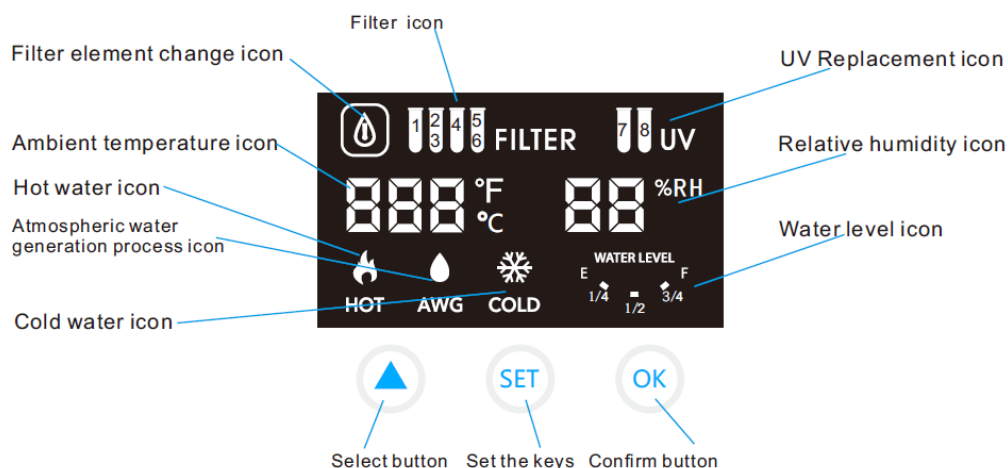

7.1: Filter element change icon-The icon flashes when the machine is in trouble, and does not shine when the fault is removed

7.2: Ambient temperature icon - measures the temperature around the device in degrees Celsius [°C] or Fahrenheit [°F].

7.3: Hot water icon - icon will flashes until water inside the tank heats up. Stays light on when water is heated to 92°C.

7.4: Atmospheric water generation process icon - While A20 is running and producing water, the icon stays light on

7.5: Cold water icon - icon will flash until the water inside the tank is cooled. Remains light on when the water is cooled to 6°C.

7.6: Relative humidity icon- shows the relative humidity in the surrounding area as a percentage [%]. Please be noted that A20 generates clean drinking water from 30% humidity above

7.7: Water level icon - shows the amount of water in the upper stainless-steel tank in liters [L], scale consists of 4 sections, 1/4 stands for about 3.75L of the total 12L of the upper tank. A20 can continue produce water till the tank gets full. Drain will makes the bar disappear, water production fills it again.

7.8: Select button\Set the keys\Confirm button - Reset flashing filter warning

---

## **8. INITIAL COMMISSIONING**

- 8.1. Unpack the cardboard box, remove the polystyrene cover and remove foil packaging of the device. Please keep the original packaging for possible warranty.
- 8.2. After unpacking, wait at least 24 hours before A20 plug into socket, failure to do so may damage the compressor.
- 8.3. Make sure A20 is not damaged or battered.
- 8.4. A20 must be located indoor, vertically and fixed on a flat floor
- 8.5. A20 is equipped with wheels at the lower rear side for easy moving on the floor
- 8.6. Place A20 in the space at least 30 cm from any walls or other structures from all sides and good air circulation
- 8.7. Before connecting A20, check the tightness of all filters (Figure 1.2-4)
- 8.8. Connect A20 to an electrical outlet that is provided with a circuit breaker at least 10A
- 8.9. We recommend flushing after prolonged shutdown (see 11.1 Flushing the device)
- 8.10. We recommend connecting another source of water (see 12. Connection of additional water sources)
- 8.11. Remove the plastic film from the control panel display
- 8.12. A20 is now ready for use.

## **9. DISPENSING OF WATER**

- 9.1. A20 dispenses clean drinking water only after operational irrigation, i.e. filter irrigation and filling 1/4 of the upper tank, which corresponds to approx. 2.5 liters of water, such volume of water is minimal to ensure the correct operation of water recirculation according to the conditions of water production
- 9.2. The water heating and cooling switches must be on for at least 30 minutes to prepare the water to the required temperatures of 6°C (cold) and 92°C (warm)
- 9.3. Clean drinking water flows from the dispenser nozzle of HL-A20L
- 9.4. Hold a glass or other water container under the dispenser nozzle of A20, or stand drip tray
- 9.5. Press the anti-hot button of the hot tap and push the handle of the hot tap with the cup to get hot water.
- 9.6. Use the glass to push the handle of the cold tap to take cold water.
- 9.7. Please be noted that hot and cold water is only available when the heating and cooling switches are turned to the "ON" position on the back of A20.

---

## 10.CHANGE FILTERS

A20 produces clean drinking water from the air by passing water through the filtration. Please follow the recommended filter change schedule to ensure the best water quality. The filter connectors are equipped with non-return valves. A20 will detect when it is time to replace the filter and will show the filter number ① - ⑧ on the display. Table below shows the recommended filter replacement schedule and the number of filters in A20.

Air Filter.....	(*Every 3 months)
Bottom Tank LED-UV Lamp Filter.....	(Every 18 months)
Sediment Filter .....	(Every 6 months)
Pre-Carbon Filter .....	(Every 6 months)
Ultra-Fine Membrane Filter.....	(Every 12 months)
Mineral filter.....	(Every 12 months)
Electropositive Membrane filter .....	(Every 12 months)
Top Tank LED-UV Lamp Filter.....	(Every 18 months)
Softening Filter .....	(Every 6 months)

\* Replacement depends on the degree of soiling or filter failure

### **Reset flashing filter warning**

Press "SET" button 3 seconds and then press "Select Button" to Select the icon of the blinking filter element. After selecting, press "OK" button to clear the memory time of the current filter element and then start to remember the life of the newly replaced filter element.

#### **10.1. Clean ① Air filter**

- Unplug A20 (Figure 1.1-1)
- Pull out the air filter (Figure 1.1-2) and clean the dust on the surface of air filter directly with tap water or air, and then put it into the machine after cleaning.
- Reset the flashing filter warning NO.1 (see 10. "Resetting flashing filter warning")



Figure 1.1-1

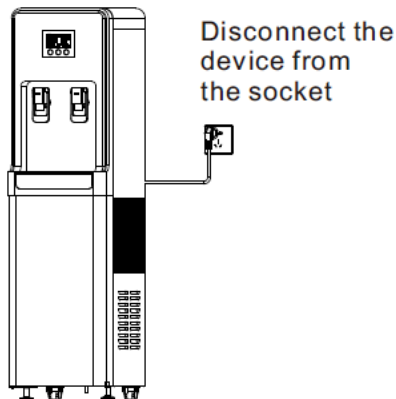
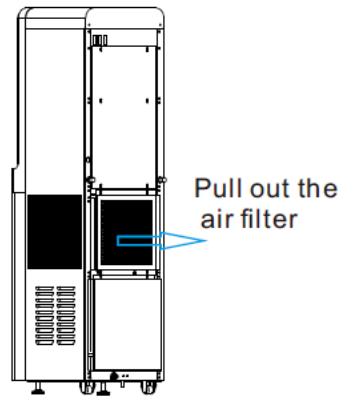

Figure 1.1-2



## 10.2. Replace water filters ② - ⑥

- a) Disconnect the plug (Figure 1.2-1)
- b) Open the front door on the right side of A20 (Figure 1.2-2)
- c) Remove the filter by turning counter clockwise (according to arrows on filter) and pull downwards (Figure 1.2-3)
- d) Keep in mind that filters are containing water and its removal may cause slight leakage of water, this is not a problem
- e) Insert new filter in place of the original by pressing upwards and turning it clockwise to fasten the filter (Figure 1.2-4)
- f) Make sure filter is properly tightened around the whole perimeter of the connection point
- g) Close the front door
- h) Reset the flashing filter warning - NO. 2 - 6 (see 10. "Resetting flashing filter warning")

Note: If you are replacing multiple filters, change water filters one by one

Figure 1.2-1

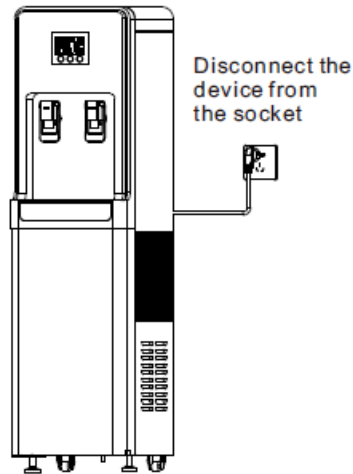

Figure 1.2-2

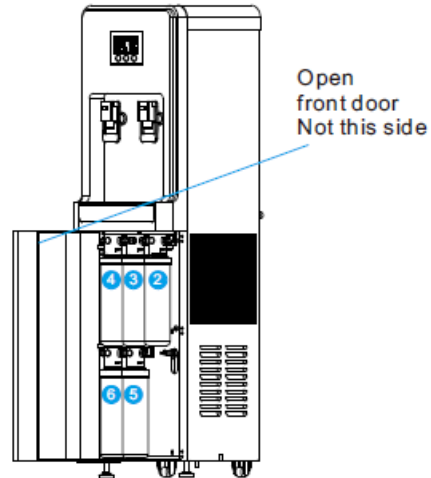

Figure 1.2-3

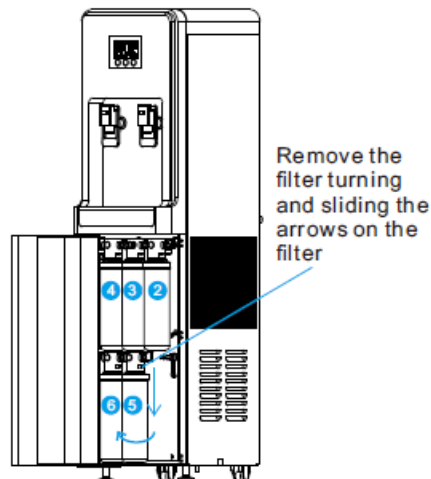
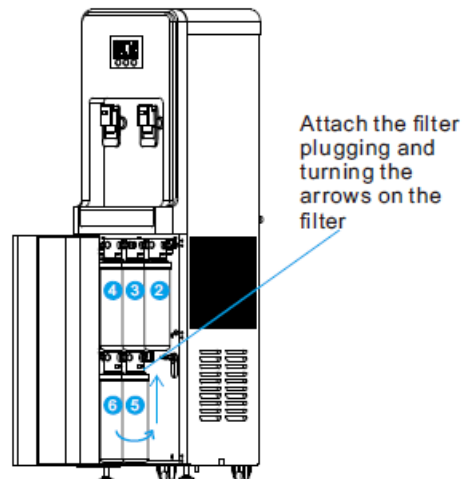

Figure 1.2-4



### 10.3. Replacing ⑦ LED UV lamp of the bottom tank

- Unplug A20 from the wall socket (Figure 1.3-1)
- Using a screwdriver or manually remove both screws from the back cover (Figure 1.3-2)
- Grasp the handle of the lower tank and slowly pull it towards you. Do not disconnect the tube and connectors, pour the remaining water out of the tank by tilting it (Figure 1.3-3)
- Loosen the LED-UV lamp nut from the underside with an adjustable wrench, disconnect the LED-UV lamp connector, remove the old LED-UV lamp (Figure 1.3-4)
- Put the new LED-UV lamp back into the tank and screw in with an adjustable wrench
- Check the connection of the new LED-UV lamp connector and its gasket (to test for leaks, pour water from the container back into the lower tank), carefully insert and then fasten the screws the rear lower cover
- Reset the blinking filter warning – NO. 7 (see 10. "Resetting flashing filter warning")

Figure 1.3-1

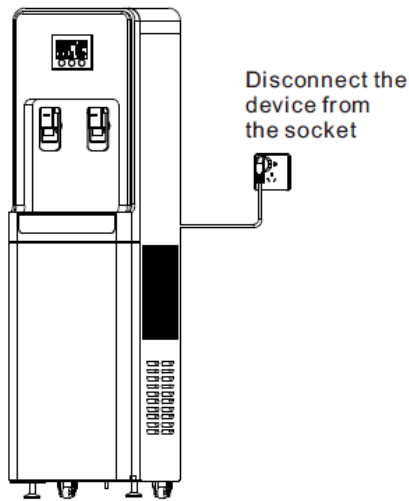

Figure 1.3-2

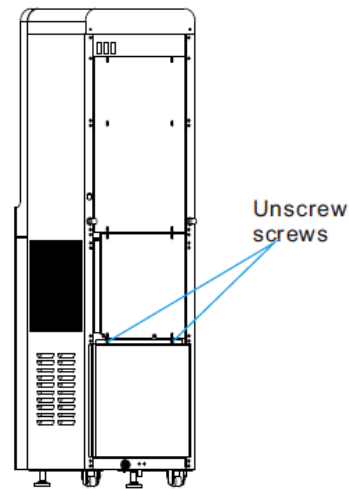

Figure 1.3-3

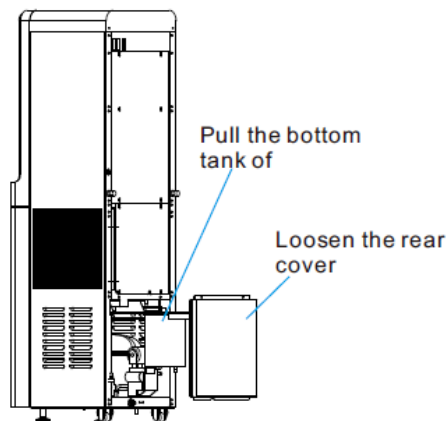
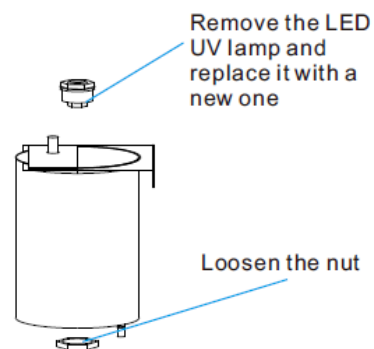

Figure 1.3-4



#### 10.4. Replacing ⑧ LED-UV lamp of the top tank

- a) Unplug A20 from the wall socket (Figure 1.4-1)
- b) Open the drain valve of the cold and hot water tanks and empty the water stored in the water tank (Figure 1.4-2)
- c) Loosen the screws with a screwdriver and remove the cover and rear baffle (Figure 1.4-3)
- d) Lift the lid of the tank up (Figure 1.4-4)
- e) Loosen the LED-UV lamp nut from the underside with an adjustable wrench, disconnect the LED-UV lamp connector, remove the old LED-UV lamp (Figure 1.4-5)
- f) Put the new LED-UV lamp back into the tank and screw in with an adjustable wrench
- g) Check the connection of the new LED-UV lamp connector and its gasket (to test for leaks, pour water from the container back into the lower tank), carefully insert and then fasten the screws the rear lower cover
- h) Reset the blinking filter warning – NO.8 (see 10.3 "Reset the blinking filter warning")
- j) Personal safety concerns require a professional replacement

Figure 1.4-1

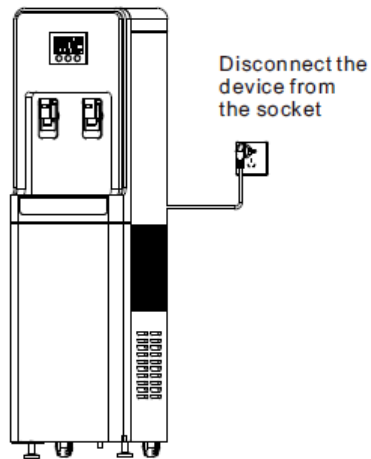

Figure 1.4-2

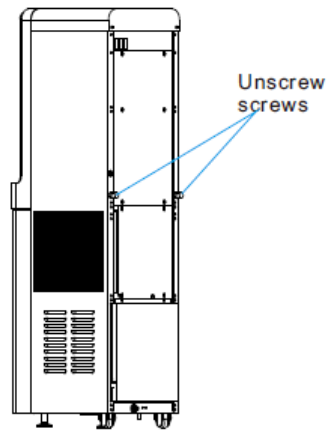

Figure 1.4-3

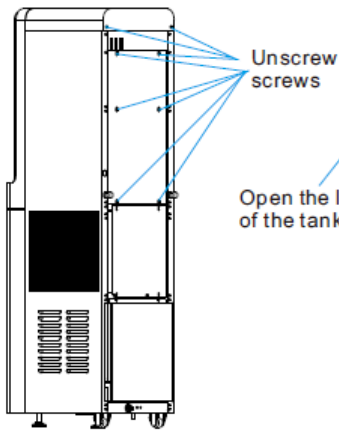

Figure 1.4-3

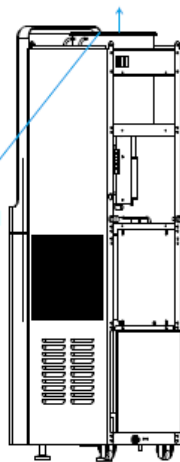
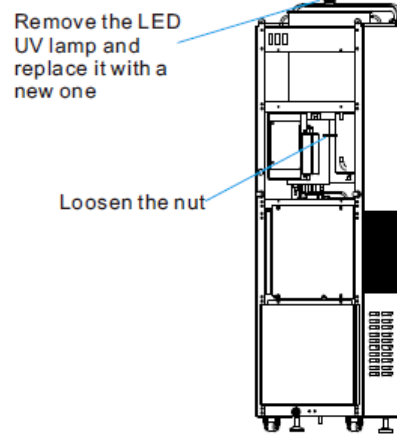

Figure 1.4-5



## 11. THE FLUSH, CLEANING AND DISINFECTION.

- 1) Always wipe A20 with clean, soft and damp cloth.
- 2) Use chemical cleaning agents to clean stainless steel tanks
- 3) If A20 is switched off for more than two days, drain the water from all tanks and filters and then rinse before using it again.
- 4) If A20 is switched off for longer than one week, suggest to replace water filters and machine should be disinfected

Figure 2.1-1

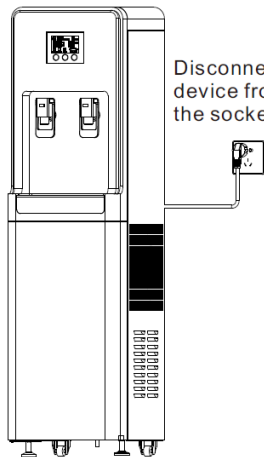

Figure 2.1-2

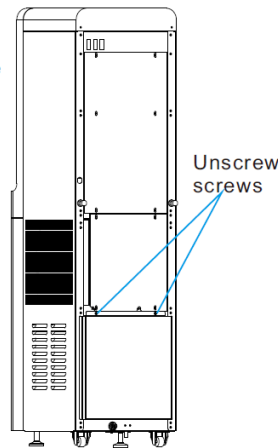
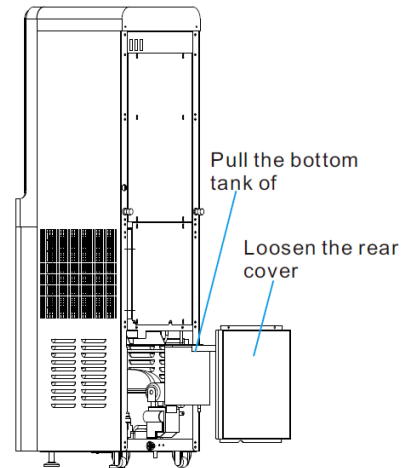

Figure 2.1-3



### 11.1. Flushing the device

- a) This step will require 10 liters of purified or distilled water
- b) If A20 is connected to an additional water supply, then turn the pressure valve lever to the “CLOSED” position and follow the next steps, otherwise leave the lever in the “OPEN” position and let the water automatically pour into the tank (the water level indicator icon will show one division), then turn the valve to the “CLOSED” position, continue according to h) and then open the valve to the “OPEN” position, ending with d)
- c) Using a hand or a screwdriver, remove both screws from the back cover (Figure 2.1-2)
- d) Grasp the handle of the lower tank and slowly pull it towards you, do not disconnect the tube and connectors, pour the remaining water out of the tank by tilting it (Figure 2.1-3)
- e) Slowly fill the bottom tank with clean or distilled water
- f) Let the pump drain the water from the bottom tank and then refill, repeat this step up to 10 liters of distilled or purified water
- g) Carefully insert the lower tank and fasten the rear lower cover bolts
- h) Allow HL-A20L to perform a water recirculation process, which may take up to three hours
- i) A20 is now ready for use again

### 11.2. Cleaning the bottom tank

- a) Disconnect the device from the power supply (Figure 2.1-1)
- b) Use a screwdriver or manually remove the two screws from the rear cover (Figure 2.1-2)
- c) Grasp the handle of the bottom tank and slowly pull it towards you, disconnect tubing and connectors, pour the remaining water from the tank by tilting (Figure 2.1-3)

- 
- d) Wipe the walls of the tank with a clean, soft, damp cloth
  - e) Gently push the bottom tank inside and fasten bolts of the rear cover. If required, reset the flashing filter warning - NO. 7 (see 10. "Resetting flashing filter warning")

### **11.3. Device disinfection**

11.3.1 - Clean with food grade citric acid.

- 1) Shutdown the A20L.
- 2) Remove filters.
- 3) Suggest to use food grade citric acid liquid and mix it with water according to the instructions of the citric acid product. If the internal pollution is critical, it is recommended to have a higher concentration citric acid liquid. Approximately 13-15L of the total liquid needs to be prepared in advance.
- 4) Wear rubber gloves, use a soft bristled brush and cleaning cloth dipped in citric acid liquid, and clean the upper and lower water tank, especially for obvious stains.
- 5) Slowly add the citric acid liquid into the upper water tank until the water in the upper water tank is full, which also means that the cold and hot water tanks are also full.
- 6) Keep it for 30 minutes.
- 7) Drain the citric acid liquid through the drainage port at the back of the machine.

11.3.2 - Clean with tap water after steps of using food grade citric acid liquid.

- 1) Restore all components of A20L, cover the upper water tank, and install filters into the machine.
- 2) Power on HL-A20.
- 3) Add tap water into the lower water tank until the screen shows the water level is Full.
- 4) Drain the water through the drainage port at the back of the machine.
- 5) Repeat the process 3 times.
- 6) During the fourth operation, get water from the hot and cold water faucets, throw away the first water directly, and check if there are any mucus or bad smell in the second water.

If not, it means the problem has been resolved.

If there is still any, it may indicate that the current filters have gone bad and need to be replaced.

---

## 12.CONNECTION OF ADDITIONAL WATER RESOURCES

Setting contents: Pressure hose blue 4,5m, pressure water valve 1/2'

- a) Remove the plug from the additional water supply at the back of the device by pushing the gray O-ring apart, if this plug is missing, contact your supplier
- b) Install the pressure valve into a 1/2' water supply outlet using a Teflon thread or tape keep in mind that the person's professional (plumber) is required for this step and some countries may require pressure test of installed valve, maximum permissible pressure in the pipeline is 4 bar.
- c) Please be noted that the connection for the valve from the connection set may vary, it may be of a size other than 1/2', use a brass adapter or adapter (not included) Insert the supplied pressure blue hose into the inlet of the additional water supply and attach the other end of the hose by tightening the nut to the pressure valve
- e) Turn the pressure valve lever to the "OPEN" position, check the joints for leaks
- f) A20 is now ready to take water from the additional water source. If you do not need to draw water from the additional water supply, turn the pressure valve lever to the "CLOSED" position and disconnect the hose from the additional water supply inlet at the back of the bottom of HL-A20L.

## 13.COMPLETE DRAINAGE

- a) If HL-A20L is connected to an optional water source, then rotate the pressure lever on the valve to "closed" position and disconnect the tubing from the supply of additional water source on the rear side of the bottom of A20
- b) Turn the heating and cooling of water to the "OFF" position
- c) Dispense all hot water using the hot water button
- d) Dispense all cold water using the cold water button
- e) Remove HL-A20L from the wall (Figure 3.1-1)
- f) Hold the vessel in the water tank hot water outlet
- g) Remove plastic cap, remove rubber stopper and completely empty the tank, the water that flows out can be used for consumption, it's not need to be disposed (Figure 3.1-2)
- h) Hold the vessel in the water drain tank of cold water and repeat step g)
- i) Replace the rubber stopper and screw the plastic caps back on each outlet
- j) Open the front door on the right hand side and gradually remove the filters by turning counter clockwise (according to the arrows on the filter) and pull downwards (Figure 1.2-3). Remove filters and close the front panel, keep in mind that filters are filled with water and when removing there may be a small water leak, this is not a problem.
- k) Use a screwdriver or manually remove the two screws from the back cover, hold the handle of the tank bottom and slowly pull it towards you; disconnect tubing and connectors, pour the remaining water from the tank by tilting (Figure 3.1-4).
- l) Gently push the bottom tank inside and fasten bolts of the rear cover.

Figure 3.1-1

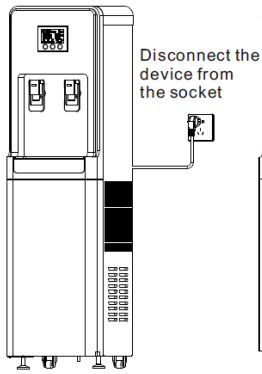

Figure 3.1-2

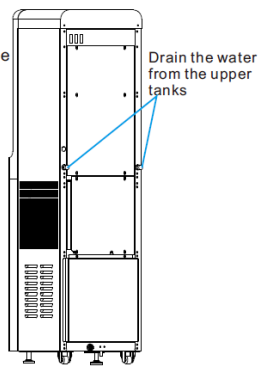

Figure 3.1-3

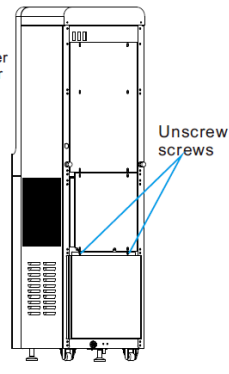
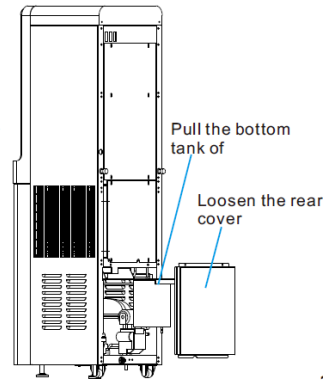
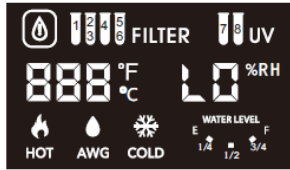

Figure 3.1-4



## 14.TROUBLE SHOOTING



LO - Low humidity around ( $\geq$  working 20%)

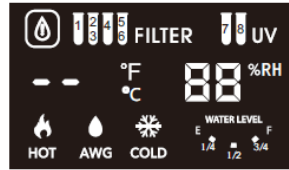

-- Error sensor temperature

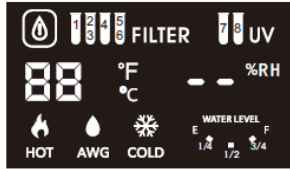

-- Error sensor temperature and humidity

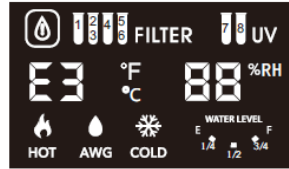

E3 - Error sensor defrost

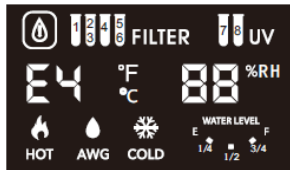

E4 - Error sensor hot water

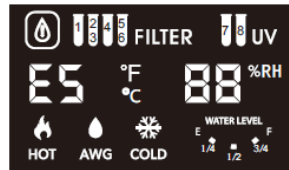

E5 - Error sensor cold water

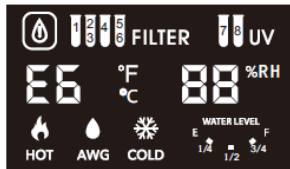

E6 - Error cooling system  
- Protection of low pressure  
- Possible refrigerant leakage

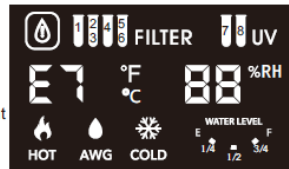

E7 - Possible water leak

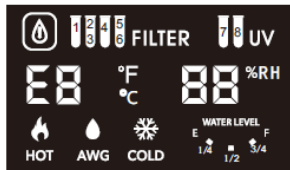

E8 - Waterway jam



---

## 15.SOLUTION OF OTHER PROBLEMS

15.1. A20 does not turn on

- a) Check that the device is connected to the power supply
- b) Check that the power plug is not damaged

15.2. The unit turns on but does not generate water

- a) Check the room temperature – A20's operating temperature range is 15°C to 45°C
- b) Check humidity - Minimum relative humidity - 30%
- c) Check air filter for contamination - Replace as necessary
- d) Check the heat exchanger fins for contamination – A20 must be disassembled for this inspection which can only be done with an authorized service center.

Be noted: Please disconnect A20 from the power supply before carrying out any service or maintenance work.

15.3. A20 operates noisy, vibrates or seeps water

- a) Check that A20 is in a vertical position on a flat surface
- b) Check that the internal condensate collector and adapter are clean - The unit must be disassembled for such inspection which can only be done with an authorized service center.

If A20 still does not operate properly after performing the above steps, contact your supplier. Only professional technicians can carry out work related to the cooling and electrical system.

## 16.TECHNICAL SPECIFICATIONS

A20 can produce 20L/Day pure water from air @30°C & RH-80%.

- 1)Input Power: 470W (Production) + 500W (Heating)
- 2)Power Supply: AC 110V 60Hz / AC 220V 50Hz
- 3)Refrigerant: R134a
- 4)Filtration Steps: Air Filter + Sediment Filter + Pre-Carbon Filter + Ultra-Fine Membrane Filter + Mineralization Filter + Electropositive Membrane filter + 2 LED-UV lamps.
- 5)Preset Hot 92°C & Cold 6°C
- 6)Working Temperature: 15-45°C
- 7)Working Humidity: RH 30% above
- 8)Net Dimension & Weight: 37.5\*30.7\*115.4CM, 42KG
- 9)LCD Touch Screen Display
- 10)Indoor Lifestyle and Low Noise Level

### Remark:

*Appliances must be disposed of at a designated recycling point for the disposal of electrical and electronic equipment.*

*It is required by law that all used electronic products (which includes products containing ultraviolet lamps) must be recycled/disposed-of separately from everyday household waste.*